

**REPAIR PARTS MANUAL**  
**MODEL NUMBER SB524C**  
**Snow Thrower**

---



**Electrolux**

# REPAIR PARTS

# AUGER HOUSING / IMPELLER ASSEMBLY

SNOW THROWER - - MODEL NUMBER SB524C (PRODUCT NUMBER 964 77 68-00)

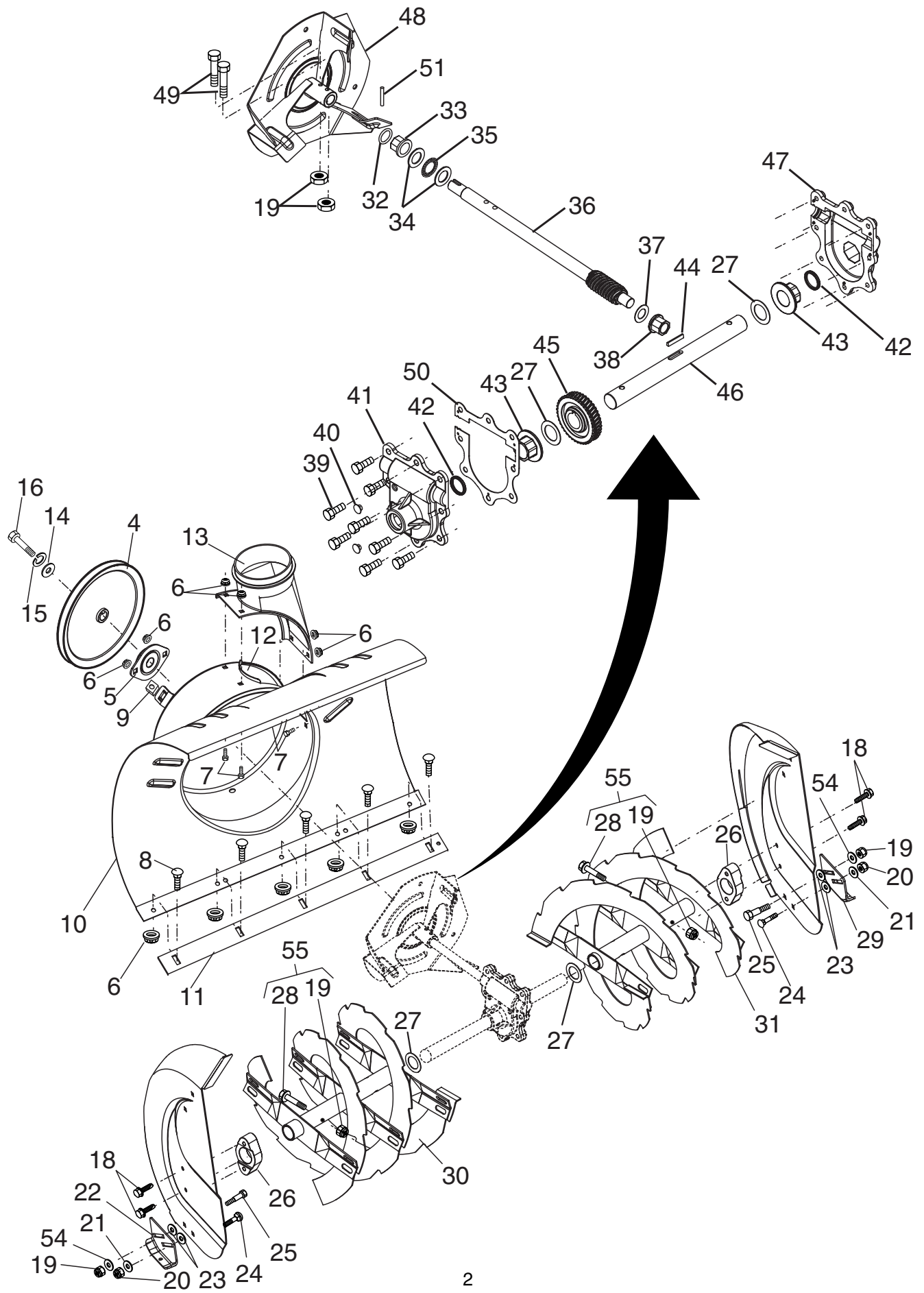

**REPAIR PARTS****AUGER HOUSING / IMPELLER ASSEMBLY****SNOW THROWER - - MODEL NUMBER SB524C (PRODUCT NUMBER 964 77 68-00)**

KEY NO.	PART NO.	DESCRIPTION
4	532 19 10-79	Pulley, Impeller
5	532 18 89-09	Bearing Assembly, Flange
6	532 15 53-77	Nut, Hex Flange 5/16-18
7	532 18 03-55	Bolt, Flat Head, Carriage 5/16-18 x 5/8
8	872 27 05-05	Bolt, Carriage 5/16-18 x 5/8
9	532 17 88-20	Nut, Cage 3/8-16
10	532 18 45-32	Housing, Auger
11	532 18 40-96	Bar, Scraper
12	532 18 40-95	Bracket, Corner Discharge
13	532 17 53-22	Base, Discharge Chute
14	819 11 15-07	Washer, Flat
15	810 04 05-00	Washer, Lock 5/16
16	874 95 05-12	Screw, Hex Head 5/16-18 x 3/4
18	532 17 95-82	Screw, Hex Head 5/16 x 1
19	873 80 04-00	Nut, Hex Lock 1/4-20
20	873 80 05-00	Nut, Hex Lock 5/16-18
21	532 15 54-15	Washer, Flat
22	532 18 40-94	Skid Plate, RH
23	532 17 92-46	Washer, Nylon, Friction
24	872 27 05-06	Bolt, Carriage 5/16-18 x 3/4
25	532 18 56-00	Bolt, Shoulder
26	532 17 46-58	Bearing, Auger
27	532 17 46-97	Washer, Thrust, 1"
28	532 19 20-90	Bolt, Shear
29	532 18 40-93	Skid Plate, LH
30	532 19 29-10	Auger Assembly, RH
31	532 19 29-09	Auger Assembly, LH
32	532 17 46-99	O-Ring
33	532 17 47-00	Bushing, Flange 3/4
34	532 17 46-81	Washer, Thrust 3/4
35	532 17 46-84	Bearing, Thrust 3/4
36	532 17 46-60	Shaft, Impeller
37	532 17 46-83	Washer, Thrust 5/8
38	532 17 46-86	Bushing, Flange 5/8
39	532 15 00-78	Screw, Hex Head 5/16-18 x 3/4
40	532 08 64-47	Plug, Case
41	532 17 46-88	Housing, Gearbox, RH
42	532 17 46-98	Seal, Oil
43	532 17 47-01	Bushing, Flange, 1"
44	532 18 92-82	Key, Square 1/4 x 1/4 x 7/8
45	532 17 46-59	Gear, Worm
46	532 17 46-57	Shaft, Auger
47	532 17 46-87	Housing, Gearbox, LH
48	532 18 41-05	Impeller Assembly
49	874 78 04-26	Screw, Hex Head 1/4-20 x 1-5/8
50	532 17 53-11	Gasket, Gearbox
51	532 18 42-05	Pin, Roll 3/16 x 1-1/8
54	532 05 43-87	Washer
55	532 18 82-43	Kit, Shear (Contains 6 each of Key Numbers 19 and 28)

**NOTE:** All component dimensions given in U.S. inches  
1 inch = 25.4 mm

# REPAIR PARTS

# CONTROL PANEL / DISCHARGE CHUTE

SNOW THROWER - - MODEL NUMBER SB524C (PRODUCT NUMBER 964 77 68-00)

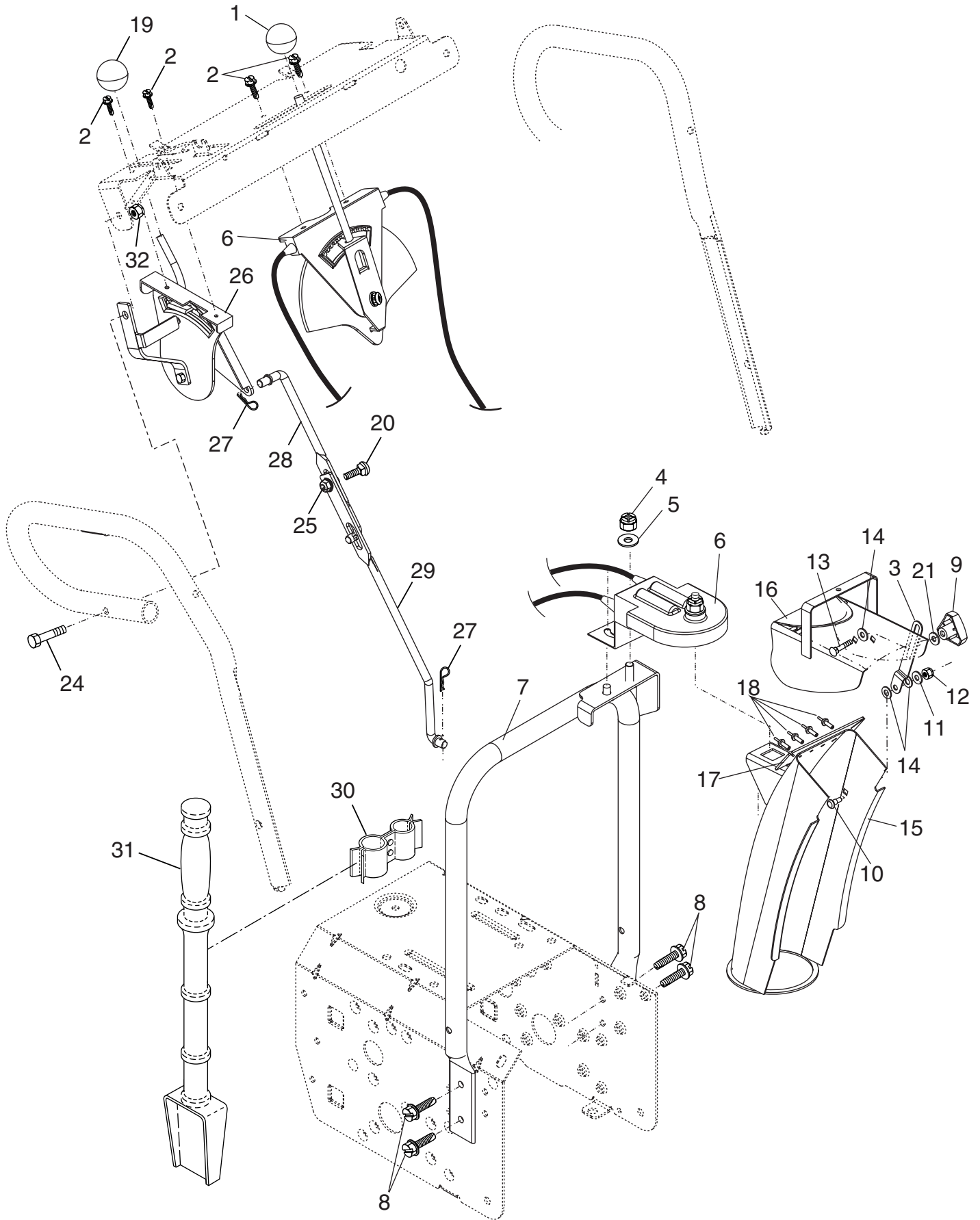

**REPAIR PARTS****CONTROL PANEL / DISCHARGE CHUTE****SNOW THROWER - - MODEL NUMBER SB524C (PRODUCT NUMBER 964 77 68-00)**

<b>KEY NO.</b>	<b>PART NO.</b>	<b>DESCRIPTION</b>
1	532 18 33-34	Knob, Lever
2	817 50 10-10	Screw #10-24 x 5/8
3	532 18 41-14	Strap, Slotted
4	873 80 06-00	Nut, Lock 3/8-16
5	819 13 13-16	Washer, Flat 3/8
6	532 17 86-59	Control Assembly, Chute Rotater
7	532 18 40-89	Support, Pivot
8	532 15 00-78	Screw, Hex Head 5/16-18 x 3/4
9	532 18 04-53	Knob, Deflector
10	532 18 56-00	Bolt, Shoulder
11	532 05 38-47	Washer, Flat 1/4
12	873 80 04-00	Nut, Lock 1/4-20
13	872 27 05-05	Bolt, Carriage 5/16-18 x 5/8
14	532 17 92-46	Washer, Nylon
15	532 18 45-33	Chute Assembly
16	532 18 45-34	Deflector Assembly
17	532 17 91-45	Seal, Deflector
18	532 12 84-15	Rivet, Blind
19	532 18 33-33	Knob, Speed Control Lever
20	872 27 05-06	Bolt, Carriage 5/16-18 x 3/4
21	532 15 54-15	Washer, Flat
24	874 78 05-28	Screw, Hex Head 5/16-18 x 1-3/4
25	532 15 53-77	Nut, Lock 5/16-18
26	532 17 92-57	Lever Assembly, Speed Control
27	532 16 96-75	Retainer, Hairpin
28	532 18 04-45	Rod, Upper, Speed Control
29	532 18 77-16	Rod, Lower, Speed Control
30	532 19 27-10	Clamp, Clean-Out Tool
31	532 19 21-99	Tool, Clean-Out
32	532 15 53-77	Nut, Lock 5/16-18

**NOTE:** All component dimensions given in U.S. inches  
1 inch = 25.4 mm

# REPAIR PARTS

# HANDLES

SNOW THROWER - - MODEL NUMBER SB524C (PRODUCT NUMBER 964 77 68-00)

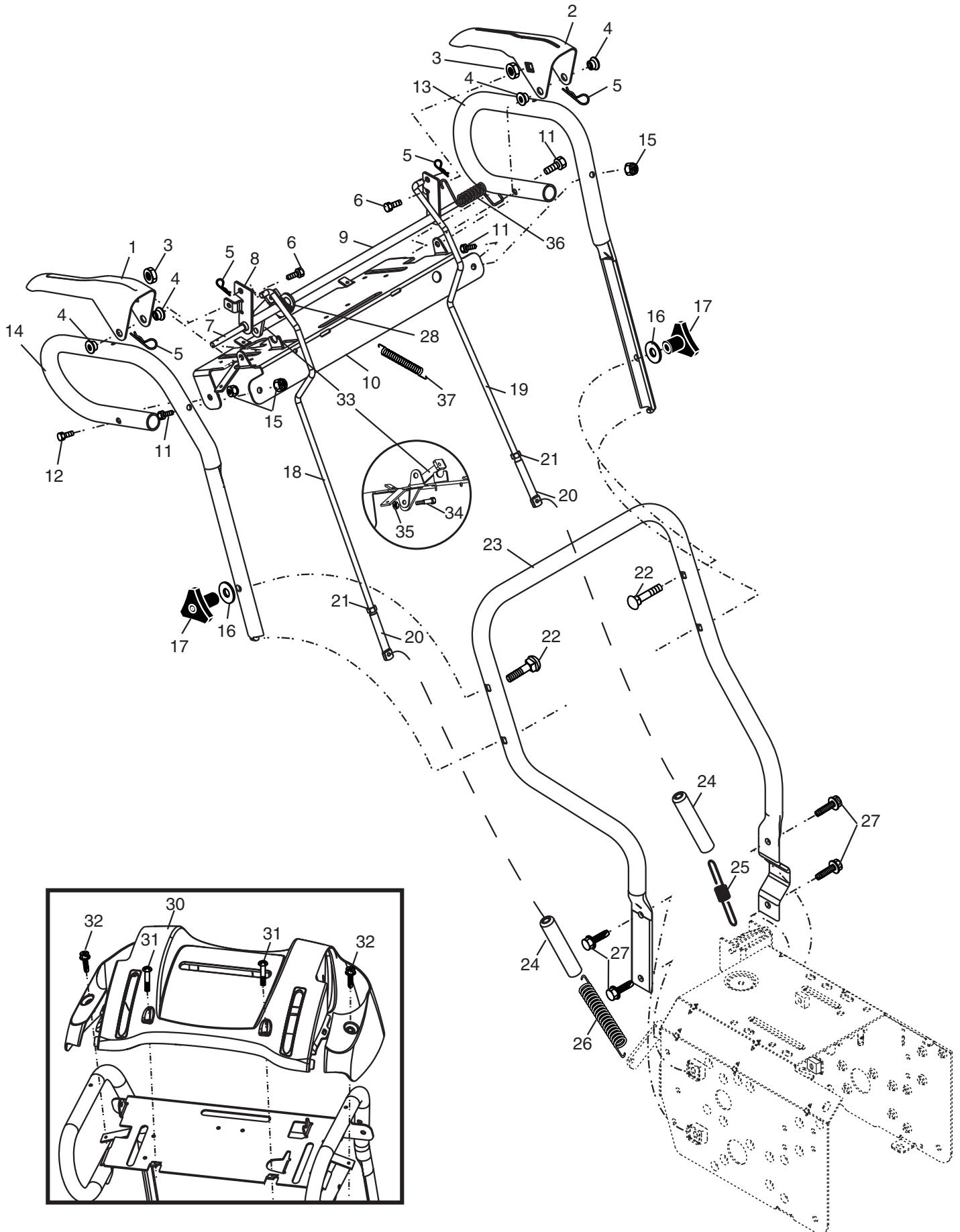

**REPAIR PARTS****HANDLES****SNOW THROWER - - MODEL NUMBER SB524C (PRODUCT NUMBER 964 77 68-00)**

<b>KEY NO.</b>	<b>PART NO.</b>	<b>DESCRIPTION</b>
1	532 18 41-10	Lever, Auger Control, RH
2	532 18 41-09	Lever, Traction Drive Control, LH
3	532 17 94-39	Nut, Cage 1/4-20
4	532 17 88-88	Bushing, Flange
5	532 16 96-75	Retainer, Hairpin
6	532 18 04-02	Screw, Hex Head 1/4-20 x 3/4
7	532 17 86-52	Rod, Interlock
8	532 18 40-03	Tube Assembly, Interlock, RH
9	532 17 86-51	Tube Assembly, Interlock, LH
10	532 18 41-06	Panel, Control
11	874 78 05-24	Screw, Hex Head 5/16-18 x 1-1/2
12	874 78 05-28	Screw, Hex Head 5/16-18 x 1-3/4
13	532 18 41-07	Handle Tube, LH
14	532 18 41-08	Handle Tube, RH
15	873 80 05-00	Nut, Lock 5/16-18
16	819 13 13-16	Washer, Flat 3/8
17	532 17 88-99	Knob, Handle
18	532 18 45-94	Rod, Auger Control
19	532 19 30-81	Rod, Traction Control
20	532 18 04-28	End, Control Rod
21	873 35 05-00	Nut, Hex, Jam 5/16-18
22	872 12 06-18	Bolt, Carriage 3/8-16 x 2-1/4
23	532 18 40-87	Handle Tube, Lower
24	532 18 04-47	Sleeve, Spring
25	532 18 09-26	Spring, Traction Drive
26	532 17 86-69	Spring, Auger Control
27	871 21 06-16	Screw, Hex Head 3/8-16 x 1
28	532 18 04-94	Clip, Panel
30	532 18 33-52	Console, Panel
31	532 17 52-62	Screw, Hex Head, Tapping #10-24 x 1-1/4
32	532 18 44-71	Screw, Hex Head, Tapping #10-24 x 1/2
33	532 18 41-11	Latch, Interlock
34	532 18 35-18	Bolt, Shoulder
35	532 06 80-38	Nut, Lock 1/4-20
36	532 17 88-31	Spring, Torsion
37	532 17 86-58	Spring, Interlock

**NOTE:** All component dimensions given in U.S. inches  
1 inch = 25.4 mm

# REPAIR PARTS

# DRIVE

SNOW THROWER - - MODEL NUMBER SB524C (PRODUCT NUMBER 964 77 68-00)

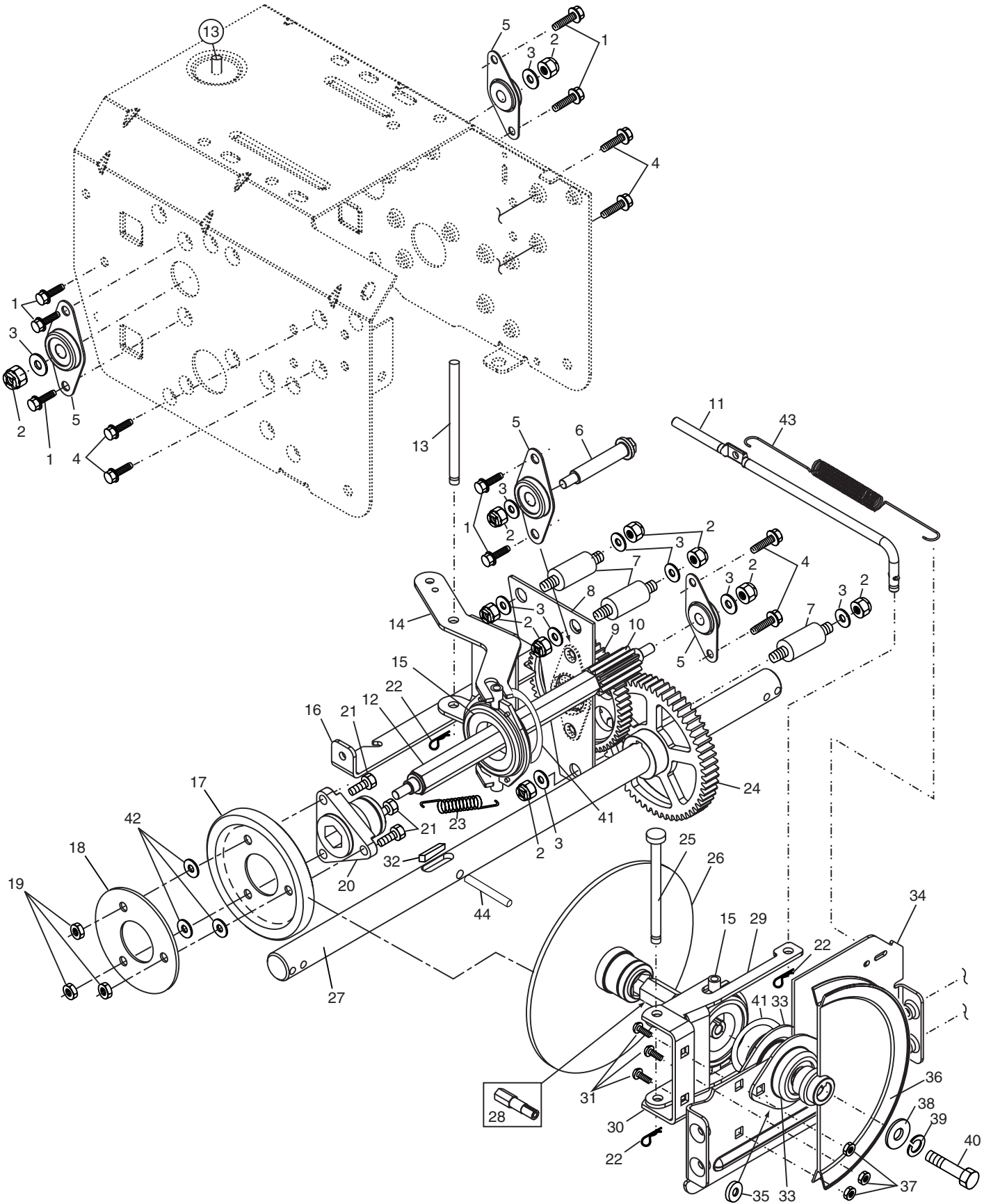



**REPAIR PARTS****DRIVE****SNOW THROWER - - MODEL NUMBER SB524C (PRODUCT NUMBER 964 77 68-00)**

<b>KEY NO.</b>	<b>PART NO.</b>	<b>DESCRIPTION</b>
1	532 14 63-15	Screw, Hex Head 5/16-18 x 3/4
2	873 80 05-00	Nut, Lock 5/16-18
3	532 15 54-15	Washer, Flat
4	817 49 05-08	Screw, Hex Head 5/16-18 x 1/2
5	532 18 00-17	Bearing, Flange
6	532 18 01-34	Shaft, Auxiliary
7	532 17 92-70	Spacer, Plate
8	532 19 29-07	Plate, Auxiliary
9	532 18 00-82	Gear, Intermediate (12/58)
10	532 18 00-65	Gear, Pinion
11	532 18 77-14	Rod, Clutch
12	532 18 00-66	Shaft, Long, Hex
13	532 17 88-07	Pin, Pivot
14	532 18 40-80	Lever, Shifter / Wheel
15	532 17 53-44	Trunnion Bearing Assembly
16	532 18 78-57	Bracket, Pivot, Shift
17	532 17 98-31	Ring, Rubber Wheel
18	532 18 40-78	Plate, Rubber Wheel
19	873 93 05-00	Nut, Lock 5/16-18
20	532 17 86-13	Hub, Rubber Wheel
21	874 76 05-14	Screw, Hex Head 5/16-18 x 7/8
22	532 08 51-79	Retainer, Hairpin
23	532 18 01-35	Spring, Bias
24	532 18 00-81	Gear, Axle (58 Teeth)
25	532 17 86-95	Pin, Pivot Lever
26	532 17 53-41	Plate Assembly, Drive
27	532 17 93-52	Shaft, Axle
28	532 17 53-40	Shaft, Short Hex
29	532 18 40-77	Lever, Shifter Plate
30	532 18 40-76	Bracket, Shifter Support
31	872 27 05-05	Bolt, Carriage 5/16-18 x 5/8
32	532 17 88-79	Key, Square 1/4 x 1/4 x 7/8
33	532 18 89-09	Bearing, Flange
34	532 18 40-75	Plate, Drive Mounting
35	532 18 25-04	Spacer, Bearing
36	532 19 10-80	Pulley, Traction Drive
37	532 15 53-77	Nut, Lock 5/16-18
38	819 11 15-07	Washer, Flat
39	810 04 05-00	Washer, Lock 5/16
40	874 95 05-12	Screw, Hex Head 5/16-18 x 3/4
41	812 00 00-12	Ring, Retaining
42	<b>532 15 54-15</b>	Washer .20 x 8.5 x 2.0
43	532 17 90-95	Spring, Return
44	532 18 42-06	Pin, Roll

**NOTE:** All component dimensions given in U.S. inches  
1 inch = 25.4 mm

# REPAIR PARTS

# CHASSIS / ENGINE / PULLEYS

SNOW THROWER - - MODEL NUMBER SB524C (PRODUCT NUMBER 964 77 68-00)

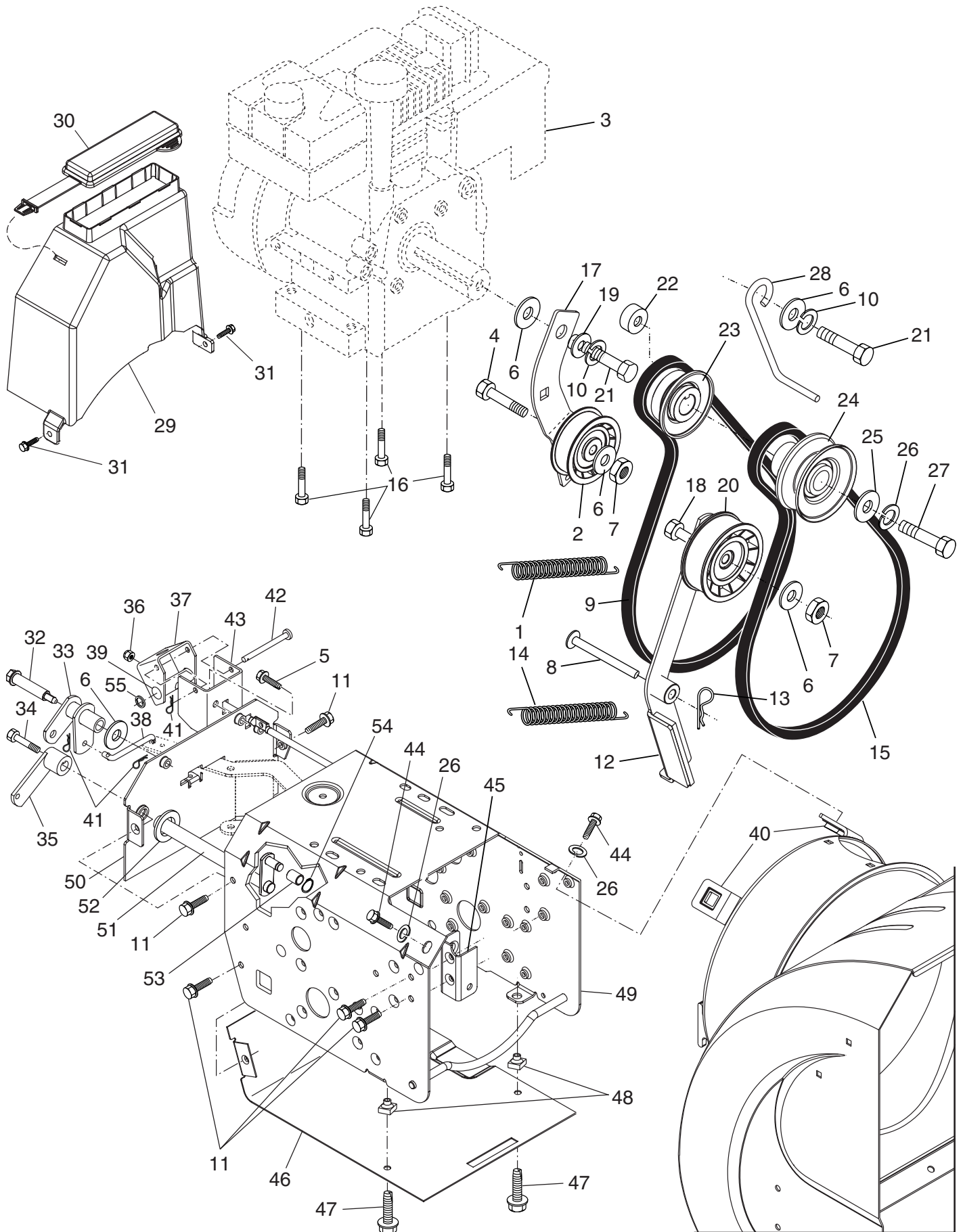

**REPAIR PARTS****CHASSIS / ENGINE / PULLEYS****SNOW THROWER - - MODEL NUMBER SB524C (PRODUCT NUMBER 964 77 68-00)**

<b>KEY PART NO.</b>	<b>PART NO.</b>	<b>DESCRIPTION</b>	<b>KEY PART NO.</b>	<b>PART NO.</b>	<b>DESCRIPTION</b>
1	532 18 10-44	Spring, Traction Idler	27	532 85 10-84	Screw, Hex Head 3/8-24 x 1-3/8
2	532 18 05-22	Pulley, Idler (2-1/4)	28	532 15 54-52	Guide, Belt
3	- - -	Engine, Tecumseh, Model Number OH195SA (Order parts from Engine manufacturer)	29	532 19 21-93	Cover, Belt
4	874 78 05-20	Screw, Hex Head 5/16-18 x 1-1/4	30	532 17 88-30	Cover, Toolbox
5	532 15 00-78	Screw, Hex Washer Head 5/16-18 x 3/4	31	817 49 04-08	Screw, Hex Head 1/4-20 x 1/2
6	532 05 92-89	Washer, Flat	32	532 17 92-56	Bolt, Shoulder 5/16-18
7	873 93 05-00	Nut, Jam, Lock 5/16-18	33	532 18 78-53	Bellcrank Shifter
8	532 17 53-30	Pin, Idler Pivot	34	532 18 04-01	Screw, Hex Head 1/4-28 x 3/4
9	532 17 90-92	V-Belt, Traction Drive	35	532 17 92-40	Arm, Auger Control
10	810 04 05-00	Washer, Lock 5/16	36	873 80 05-00	Nut, Lock 5/16-18
11	<b>817 49 05-08</b>	Screw, Hex Washer Head 5/16-18 x 1/2	37	532 18 40-86	Bellcrank Assembly
12	532 17 92-59	Idler Arm, Impeller	38	532 18 71-01	Link, Speed Control
13	532 08 51-79	Retainer, Hairpin	39	532 19 21-10	Trunnion, Pivot Bracket
14	532 17 88-28	Spring, Brake	40	532 17 88-90	Nut, Cage 3/8-16
15	532 18 35-33	V-Belt, Impeller Drive	41	532 70 02-79	Hairpin, Cotter 3/32 x 1/2
16	532 19 23-06	Screw, Hex Head 3/8-16 x 1-1/4	42	532 17 90-65	Pin, Pivot Bracket
17	532 18 48-04	Arm, Idler	43	532 18 40-85	Bracket, Bellcrank
18	874 78 05-24	Screw, Hex Head 5/16-18 x 1-1/2	44	874 78 06-24	Screw, Hex Head 3/8-16 x 1-1/2
19	532 17 53-31	Bushing, Idler Pivot	46	532 18 40-84	Pan, Frame Bottom
20	532 18 05-23	Pulley, Idler (2-3/4)	47	871 02 05-12	Screw, Hex Head 5/16-18 x 3/4
21	874 61 05-16	Screw, Hex Head 5/16-18 x 1	48	532 18 11-56	Nut, Speed 5/16-18
22	532 17 93-71	Spacer, Engine Pulley	49	532 18 45-30	Frame Assembly
23	532 18 04-78	Pulley, Engine, Traction Drive	50	532 18 83-70	Plate, Frame End
24	532 17 91-57	Pulley, Engine, Impeller Drive	51	532 19 29-08	Shaft, Auger Control
25	532 06 27-35	Washer, Flat 3/8	52	532 05 70-79	Washer, Hardened
26	532 85 02-63	Washer, Lock 3/8	53	532 19 22-75	Roller
			54	532 19 21-47	Ring, Crescent
			55	812 00 00-02	E-Ring

**NOTE:** All component dimensions given in U.S. inches.  
1 inch = 25.4 mm

# REPAIR PARTS

# WHEELS

SNOW THROWER - - MODEL NUMBER SB524C (PRODUCT NUMBER 964 77 68-00)

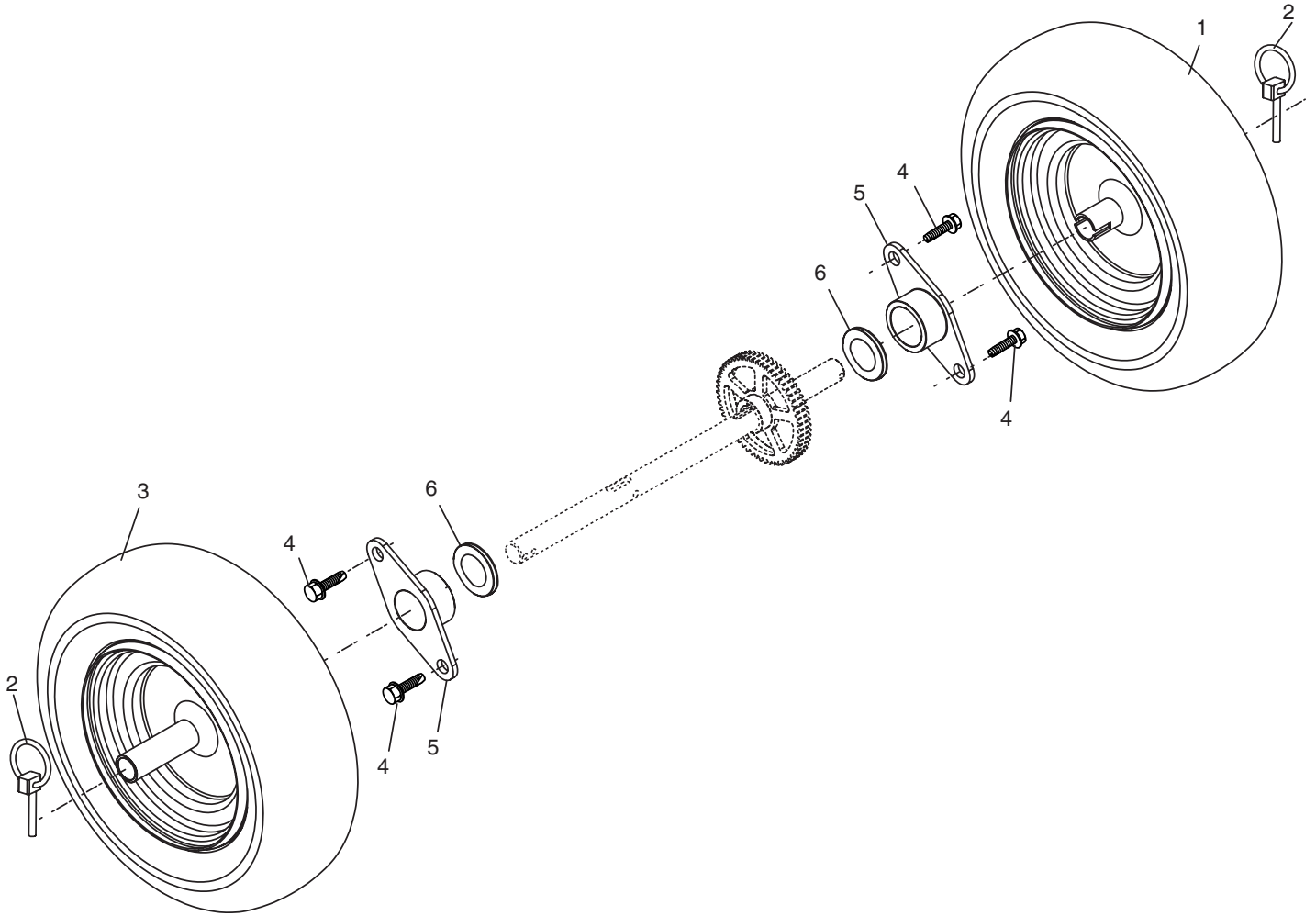

# REPAIR PARTS

# WHEELS

## SNOW THROWER - - MODEL NUMBER SB524C (PRODUCT NUMBER 964 77 68-00)

KEY NO.	PART NO.	DESCRIPTION
1	532 18 78-33	Wheel Assembly, 16", LH
2	532 15 54-43	Pin, Klik 1/4
3	532 18 78-65	Wheel Assembly, 16", RH
4	532 14 63-15	Screw, Hex Head 5/16-18 x 1/2
5	532 17 98-30	Bearing, Axle
6	532 17 46-97	Washer, Thrust, 1"

**NOTE:** All component dimensions given in U.S. inches  
1 inch = 25.4 mm

**REPAIR PARTS**

**DECALS**

**SNOW THROWER - - MODEL NUMBER SB524C (PRODUCT NUMBER 964 77 68-00)**

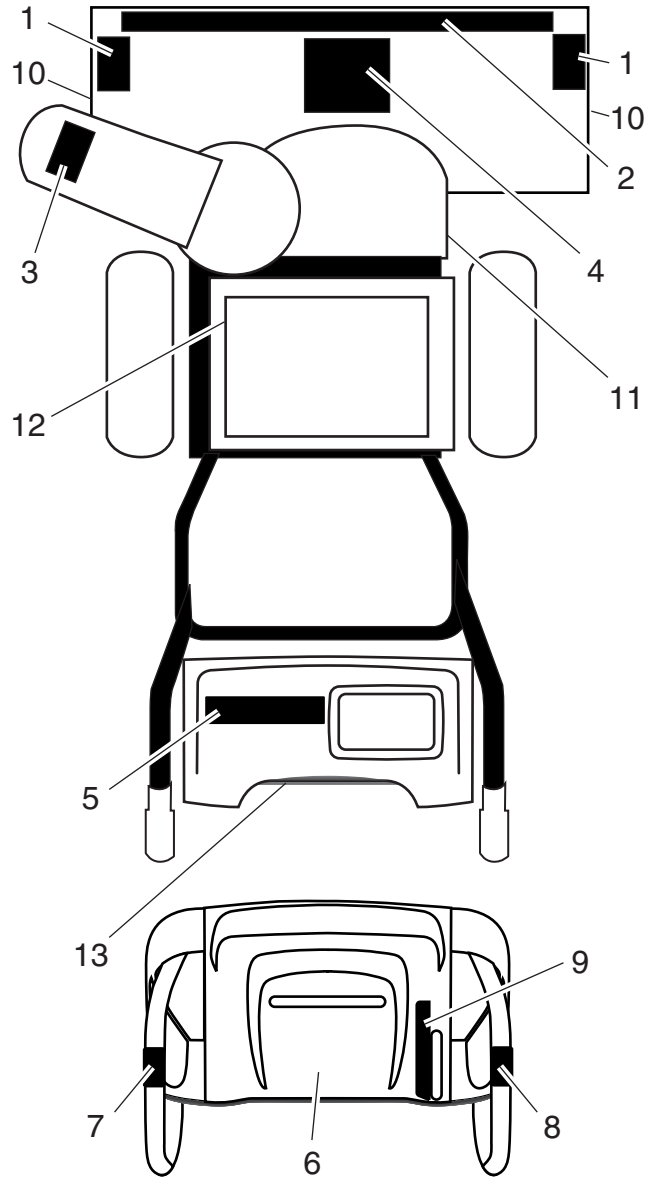

**SNOW THROWER - - MODEL NUMBER SB524C (PRODUCT NUMBER 964 77 68-00)**

<b>KEY NO.</b>	<b>PART NO.</b>	<b>DESCRIPTION</b>
1	532 18 40-26	Decal, Danger
2	532 18 79-77	Decal, Rally, Large
3	532 18 40-27	Decal, Danger, Deflector
4	532 18 40-45	Decal, Danger
5	532 18 38-72	Decal, Rally, Small
6	532 18 40-30	Decal, Instruction
7	532 18 40-36	Decal, Traction Lever
8	532 18 40-35	Decal, Auger Lever
9	532 18 40-32	Decal, Speed Control
10	532 18 41-24	Decal, Height Adjust
11	532 18 40-28	Decal, Belt Guard
12	532 18 40-37	Decal, Fuel Shut-Off
13	532 18 04-33	Decal, Sound Level
--	532 18 42-84	Operator's Manual, European
--	532 18 42-86	Operator's Manual, Scandinavian
--	532 18 42-89	Operator's Manual, East Bloc Euro
--	532 19 31-75	Repair Parts Manual, English

**NOTE:** All component dimensions given in U.S. inches  
1 inch = 25.4 mm

## LIMITED WARRANTY

The Manufacturer warrants to the original consumer purchaser that this product as manufactured is free from defects in materials and workmanship. For a period of two (2) years from date of purchase by the original consumer purchaser, we will repair or replace, at our option, without charge for parts or labor incurred in replacing parts, any part which we find to be defective due to materials or workmanship. This Warranty is subject to the following limitations and exclusions:

1. This warranty does not apply to the engine. Please contact your nearest dealer where they will send the machine to the engine manufacturer.
2. Transportation charges for the movement of any power equipment unit or attachment are the responsibility of the purchaser. Transportation charges for any parts submitted for replacement under this warranty must be paid by the purchaser unless such return is requested by your dealer.
3. Battery Warranty: On products equipped with a Battery, we will replace, without charge to you, any battery which we find to be defective in manufacture, during the first ninety (90) days of ownership. After ninety (90) days, we will exchange the Battery, charging you 1/12 of the price of a new Battery for each full month from the date of the original sale. Battery must be maintained in accordance with the instructions furnished.
4. The Warranty period for any products used for rental or commercial purposes is limited to 90 days from the date of original purchase.
5. This Warranty applies only to products which have been properly assembled, adjusted, operated, and maintained in accordance with the instructions furnished. This Warranty does not apply to any product which has been subjected to alteration, misuse, abuse, improper assembly or installation, delivery damage, or to normal wear of the product.
6. Exclusions: Excluded from this Warranty are belts, normal wear, normal adjustments, standard hardware and normal maintenance.
7. In case of any problem within the boundaries of this warranty, contact the nearest department store, indicate the model number, serial number and the date of purchase of your machine. This warranty does not apply to accidental damages. All implicit warranties are limited to the same time frames. Or contact:

E.M. Services  
54 Rue Lambrechts  
92400 Courbevoie  
France  
Telephone: (1) 46678078  
Fax: (1) 46678095

THIS WARRANTY DOES NOT APPLY TO INCIDENTAL OR CONSEQUENTIAL DAMAGES. ANY IMPLIED WARRANTIES ARE LIMITED TO THE SAME TIME PERIODS STATED HEREIN.